



▶ **AIR COOLED SOLID STATE UHF TRANSMITTERS FOR ANALOG AND DIGITAL TV**

- ▶ **Dual Cast capability: digital TV and analog TV in the same transmitter**
- ▶ **Latest LDMOS Technology for Power Amplifier**
- ▶ **Digital standards DVB-T/H, ATSC, ISDB-T/T_B**
- ▶ **Fully broadband covering the entire UHF band IV-V**
- ▶ **Low Power Consumption**

AIR COOLED SOLID STATE UHF TRANSMITTERS FOR ANALOG AND DIGITAL TV

Electrosys presents its line of advanced Solid State Television Transmitters with latest state-of-the-art technology.

The transmitters operate in UHF band IV/V and are available in output power classes from 200W up to 10kW for analog TV, classes from 50W up to 3,5kW for DVB-T/H and ISDB-T/TB, and from 100W up to 5kW for ATSC.

The transmitter configurations range from single rack to multi-cabinet transmitters while the system architecture includes dual drive, passive reserve and active reserve configurations.

The state-of-the-art and reliability of these transmitters is guaranteed by Electrosys' vast experience in RF systems, know-how in implementation of sophisticated technologies, and expertise in digital signal processing, which ensures a competitive edge on our customers.

One outstanding feature of these transmitters is their Multi-Standard Capability which makes them compatible with analog and digital television system. The transmitters are practically the same for analog and digital (DVB-T/H, ATSC) broadcasting. It is possible to switch from one standard to the other by simply selecting the mode on the exciter's control display. This allows to switch between analog and digital broadcasting service at any time.

The use of latest LDMOS technology allowed Electrosys to realize the new line of air cooled transmitters giving particular attention to compactness, with minimum space requirements inside the station, and to operational costs, with an impressive power consumption reduction.

In the development phase, particular attention has been given to the realization of equipment provided with a remote management system which, besides allowing the verification of the correct operation, allows to carry out remote diagnoses on possible problems.



The systems architecture, with the use of redundancy elements, guarantees in any case the absence of service interruptions, also during technical assistance operations.

A careful selection of the components connected to the ventilation and the use of sound absorbent materials, have allowed the realization of equipments with a reduced "acoustic noise" value in compliance with the requirements by the most restrictive specifications.

TRANSMITTERS CONFIGURATIONS

Analog TV Output Power KWps	DVB-T/H Output Power KWrms	ATSC Output Power KWrms	Number of Amplifiers	RF Output Connector	Dimensions (wxdxh mm)	Weight Kg
1,5 kW	0,45 kW	0,8 kW	1	7/16"	546x760x1128	260
3 kW	0,85 kW	1,4 kW	2	7/16" or 1" 5/8	560x1160x1941	350
4 kW	1,25 kW	2,1 kW	3	1" 5/8		365
5,5 kW	1,7 kW	2,8 kW	4	1" 5/8 or 3" 1/8	560x1160x2018	390
7 kW	2 kW	3,3 kW	5		415	
10 kW	3,2 kW	5,3 kW	8	3" 1/8	1130x1160x2018	715
13 kW	4 kW	6,4 kW	10		795	

NOTE: DVB-T/H and ATSC Output Power before filter

MULTIMODE EXCITER (MEX)



Multimode is the State-of-The-Art Exciter capable of all modulation modes by means of fully digital signal processing. Only by changing the modulator card firmware, the exciter can implement analog TV (all standards), DVB-T/H, ATSC 8VSB and can operate in dual cast. Using

the MEX dual cast transmitter is very simple: it is possible to switch between digital and analog TV transmission by a simple software command (locally by means of keyboard or remotely by using HTTP web browser, SNMP or Electrosys proprietary control software).

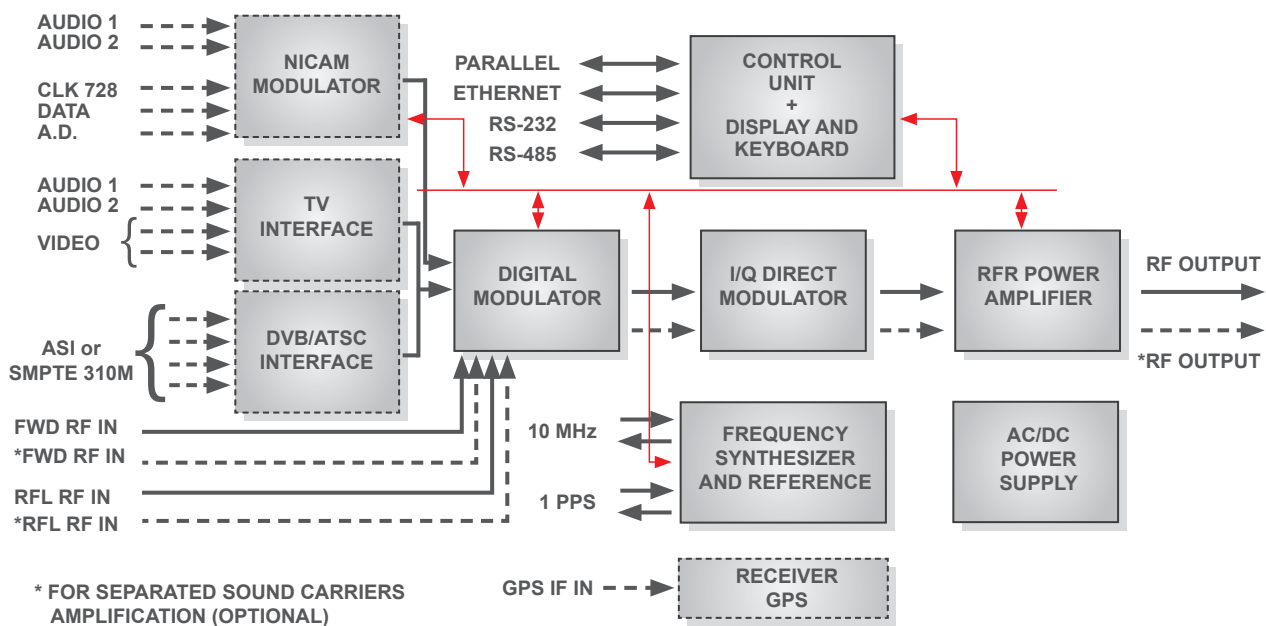

A wise use of the latest technologies, in particular the innovative single chip Modulator and the I/Q direct modulator, have enabled us to significantly reduce the complexity and to increase the reliability of the exciter.

The exciter performs the analog TV, DVB-T/H and ATSC modulation, fully compliant with the related transmission standards. Output power is 1Wrms for DVB-T/H and ATSC, and 5Wps for analog TV, appropriate for high power RF amplification.

In order to improve the transmitter RF characteristics, a digital pre-equalization is performed to compensate for the linear antenna filter distortions and a digital

pre-correction for the non-linear final HPA distortions. In DVB-T/H mode the pre-correction set up can be manual or automatic; in ATSC mode both pre-equalization and pre-correction can be manual or automatic.

An integrated GPS receiver is available when the exciter is used in DVB-T/H Single Frequency Network.

The exciter is equipped with a control unit that allows commands, configuration and parameters monitoring locally, by means of a LCD display, and remotely by means of web server and SNMP protocols. Moreover, the remote control supports TFTP and Telnet protocols for service operations, including the remote firmware upgrade of all the exciter digital parts.

AIR COOLED POWER AMPLIFIER



The new air cooled power amplifier module utilizes the latest high power LDMOS technology. The power amplifier module is fully broadband, covering the entire 470-860 MHz UHF range, employs only latest state-of-the-art LDMOS devices and is designed for DVB, DTV and Analog TV (Common and Separate Amplification).

The amplifier nominal power is 1.600W for analog TV, 450W for DVB-T/H and 800W for ATSC. Versions of the power amplifier with reduced high po-

wer RF section allow transmitters configurations with lower output power: 500W, 1kW for analog; 150W, 300W for DVB-T/H, are examples of attainable configurations.

Each module incorporates its dedicated high efficiency switch-mode DC/DC or AC/DC Power Supply. The power amplifiers require no tuning and are self-protected against VSWR, RF Input Overdrive, Over Current, Over Temperature, Over Voltage and Under Voltage.

The cooling systems are built-in air forced, performed by DC fans controlled by temperature sensor, in order to get a longer life of the fans. The air cooled power amplifiers' final stages work in AB class to reach a good compromise between introduced distortion and dissipated power with low current consumption.

The modules are hot-pluggable thanks to the use of isolated combiners, allowing safe removal and insertion without interrupting transmitter operation.

Each power amplifier incorporates its Control Logic Section, which receives and manages all information provided by RF Section and by the power supply. The Control Logic Section is designed to control directly the power amplifiers and, at the same time, to transfer information to the equipment's supervisory control logic.

TRANSMITTER CONTROL LOGIC



The control logic unit manages transmitter monitoring, control, diagnostic and both internal and external communication.

The status of the transmitter and of its major subassemblies is displayed locally in a graphical and numerical format on the control

logic unit LCD display. Moreover, history of transmitter alarms and status is stored in a control logic unit software database.

The Electrosys Supervisory System, with its Windows based software, enables a sophisticated and user-friendly remote control and management of the transmitter via a standard telephone network or an IP network.

The ESS version for telephone network sets a point to point connection between the transmitter and the remote control centre by means of a GSM or PSTN modem connected to the RS232 interface of the control logic unit.

The ESS version for IP networks (Ethernet 10/100) enables the remote control of the transmitter from one or more control centres simultaneously with application protocols HTTP, SNMP, TELNET. ESS allows not only the remote control of the complete transmitters and of its major subassemblies, but also the firmware up-grade of all Multimode Exciter programmable boards with application protocol TFTP.

TECHNICAL SPECIFICATIONS

GENERAL SPECIFICATIONS

Frequency Range	470-870 MHz
Power Supply	230V/400V +/- 15%
Relative Humidity	95% without condensation
Temperature Range	0°C to +45°C
Maximum Operating Altitude	Up to 2000 meters

INTERFACES

Local Control	Display(s) and keyboard(s)
Remote Control	Ethernet for HTTP (Web Server)/SNMP/TFTP/TELNET, RS-232, Parallel.
Optional Remote Interface	GSM Modem
Test points	RF out monitor, RF amp output, local oscillator, RF exciter output

ANALOG TV SPECIFICATION

Tv Standards	B/G/D/K/K1/M/N
Colour Systems	PAL, NTSC, SECAM
Video Input Interfaces	2 BNC 75 Ω , 1Vpp \pm 6 dB. Manual Gain or AGC on ITS line, DC Restore, White Limiter (85+95%), Sync Restore (20+30%)
Modulation Depth	5 \pm 15 %
Audio Input Interfaces	2 XLR 600 Ω /5 K Ω , balanced/unbalanced, 0 dBm-6 dB +21 dB. In wideband mode input 2 works up to 120 KHz (MPX).
Additional Audio Input Interfaces	1 BNC 50 Ω /5K Ω for MPX (up to 120 KHz) and 1 BNC 50 Ω for auxiliary services for standard M
Audio encoder mode	Mono/Stereo/Dual Sound/Wide Band/Auto
FM Deviation	Up to 100 KHz (200 KHz for standard M), Hard Limiter 1 KHz step
NICAM audio interfaces	2 XLR 600 Ω /5 K Ω , balanced/unbalanced, 0 dBm \pm 10 dB
NICAM data interfaces	1 BNC TTL 728 Kbit/s external data, 1 BNC TTL 728 Kbit/s additional data, 1 BNC TTL 728 KHz external clock
NICAM mode	Mono/Stereo/Dual Sound/Mono+Data/External (lock to External Data or External Clock)
Frequency Reference	Internal (OCXO or integrated GPS)/Internal locked to the External (BNC 50 Ω , 10 MHz)
Bandwidth	6, 7, 8 MHz

DVB-T/H SPECIFICATIONS

DVB-T/H Input Interfaces	4 BNC 75 Ω , DVB ASI, TS 188/204 packets, continuous and burst mode
Input Bit Rate	According to EN 300 744 in SFN, Bit Rate adaptation and PCR restamping in MFN
IFFT	2K, 4K, 8K
Code Rate	1/2, 2/3, 3/4, 5/6, 7/8
Guard Interval	1/4, 1/8, 1/16, 1/32
Interleaver	2K, 4K, 8K
Constellation	QPSK, 16QAM, 64QAM
Hierarchical (Alpha)	1, 2, 4
Network	MFN, SFN
Bandwidth	5, 6, 7, 8 MHz
Frequency Reference	Internal (OCXO or integrated GPS)/Internal locked to the External (BNC 50 Ω , 10 MHz)
1 PPS	Internal (integrated GPS)/External (BNC 50 Ω , TTL)

ATSC SPECIFICATIONS

ATSC Input Interfaces	2 BNC 75 Ω DVB ASI TS 188/204 packets, continuous and burst mode, 2 BNC 75 Ω SMPTE 310M
Input Bit Rate	DVB ASI: Bit Rate adaptation and PCR restamping, SMPTE 310M: 19.392658 Mbit/s
Modulation	8 VSB
Code Rate	Trellis 2/3
Symbol Rate	10.76224 MSymb/s
Bandwidth	6 MHz
Frequency Reference	Internal (OCXO or integrated GPS)/Internal locked to the External (BNC 50 Ω , 10 MHz)



Electrosys
Loc. Sferracavallo 19/A
05018 Orvieto
Italy

Phone: +39 07361
Fax: +39 0763 336344
E-mail: sales@electrosys.it
Web: www.electrosys.it



Electrosys is a registered trademark of Electrosys s.r.l.
Trade names are trademark of the owners
Printed in Italy

Version 1.00 - February 2010

Data without tolerance is not binding
Subject to change